



RIKEN

Specialized manufacturer of the best Permanent Magnet Lifter

Permanent Magnet Lifter Manual

APPLICATION & FEATURE

Model RC (Permanent Magnetic Lifter) is mainly used to fasten or hold steel/iron workpieces during lifting or handling operations. It is capable of holding steel/iron plate and cylindrical steel.

They are widely used as hoist devices in factories but are safe and convenient in many other workplaces. easy and safe in operation, convenient for carrying goods at docksides, warehouses and within commercial and transportation industries.

By using them, you can improve working environments and practices and enhance efficiency greatly.

CONSTRUCTION

RC has a strong magnetic circuit produced by Neodymium Iron Boron (NdFeB) magnetic materials. The ON or OFF of the magnetic circuit is controlled by turning the main handle. There is a locking key in the handle to offer safe control and a V slot on the bottom surface for a cylindrical workpiece to be held in place.

SIGNAL WORDS

Note use of the following signal words DANGER, WARNING & CAUTION with safety messages. The appropriate signal word for each has been selected using the following guidelines:

DANGER

Indicates an imminently hazardous situation that, if not avoided, will result in death or serious injury. The signal word is to be limited to the most extreme situations typically for machine components which, for functional purposes cannot be guarded.

WARNING

Indicates a potentially hazardous situation that, if not avoided, could result in death or serious injury, and includes hazards that are exposed when guards are removed. It may also be used to alert against unsafe practices.

CAUTION

Indicates a potentially hazardous situation that, if not avoided, may result in minor or moderate injury. It may also be used to alert against unsafe practices. Every year many accidents occur which could have been avoided by a few seconds of thought and a more careful approach to handling equipment. You, the operator can avoid many accidents by observing the following precautions in this manual. To avoid personal injury, study the following precautions and insist those working with you, or you yourself, follow them.

Replace any Caution, Warning, Danger or Instruction safety label that is not readable or is missing.

Do not attempt to operate this equipment under the influence of alcohol or drugs. Review safety instructions with all users.

Operator should be a competent person. DO NOT ALLOW PERSONS TO OPERATE OR ASSEMBLE THIS UNIT UNTIL THEY HAVE DEVELOPED A THOROUGH UNDERSTANDING OF SAFETY PRECAUTIONS AND HOW IT WORKS.

Never exceed the limit of a life. If it's ability to do a job, or to do so safely is in question - DON'T TRY IT.

OPERATION

WARNING

Before any use or operation, you should clean the surface of the workpiece being lifted and ensure that the bottom of the lifting magnet is free of any dirt or debris; such as rust and or metallic burr.

Place the lifter on the surface of the workpiece and make sure the centreline of the lifter and the workpiece overlap clearly. Then turn the handle from OFF to ON until the inner slide key of handle passes the lifter's stop pin.



RIKEN

Specialized manufacturer of the best Permanent Magnet Lifter

Permanent Magnet Lifter Manual

⚠ CAUTION

Make sure the handle's inner slide key is automatically locked by the stop pin. Only after all these instructions have been followed should the operator begin to use the lifting magnet.

During any lifting and handling operation, overloading is totally prohibited. It is also forbidden to pass underneath or stand under the workpiece that is being held by the magnetic lifter. The temperature of the workpiece and the surrounding area should be between no less than -40°C or no more than $+80^{\circ}\text{C}$. It is unsafe to use the lifter in an area where heavy vibration could occur or in an area that could cause an impact to the lifter during the course of use or during a lifting operation.

When lifting cylindrical workpieces, ensure the workpiece is in contact with the lifter's V slot lines. The capacity for cylindrical iron/steel is generally only 30% of the unit's rated capacity for standard flat plate e.g. plate capacity W.L.L. 100 KGS would equate to cylindrical capacity W.L.L. 30 KGS.

After every lifting or handling operation is finished, press down the button of the handle to disengage the slide key from the stop pin and accordingly turn the handle from ON to OFF until it is released. At this point the lifter is in a neutral condition and it can be safely taken away from the workpiece that was being lifted.

MAIN FACTORS FOR SAFE USE

⚠ WARNING

THE THICKNESS AND SURFACE OF THE WORKPIECE IS CRITICAL

Before EACH AND EVERY operation, it is necessary to find out its effective capacity of the lifter depending on the thickness of the item being lifted. According to STEEL THICKNESS percentage curve on the chart on this instruction guide, the user should determine the capacity and assess the lift requirement. Also care should be taken to make a clear estimate to determine the effective capacity of the lifter depending on the workpiece surface condition according to the AIR GAP percentage curve detailed in the chart on this instruction guide.

⚠ CAUTION

For assistance with the surface quality, if the roughness (Ra) is less than $6.3\mu\text{m}$, the effective lifting capacity can be as the maximum 100%. However, if the surface roughness (Ra) is above $6.3\mu\text{m}$ or even worse, the air gap between the lifter and workpiece should be closely calculated and estimated to affect the lifting capacity.

To find out the effective capacity of this AIR GAP please closely study the AIR GAP curve percentage chart on this instruction guide. Combining both factors then calculate the actual lifting capacity on this condition. The curve is also printed on both sides of each magnetic lifter.

CRITICAL SAFETY CONSIDERATIONS FOR LIFTING ANY WORKPIECE

⚠ WARNING

Taking the magnetic lifter's capacity in hand, it should be considered for low-carbon steel plate as the usual standard which has the coefficient 1.

After measurement and careful analysis, the capacity coefficient:

- * Medium-carbon steel = 0.95
- * High-carbon-steel = 0.90
- * Low-alloy steel = 0.75
- * Cast Iron = 0.50



Permanent Magnet Lifter Manual

Maintenance & Safety Notice

Before using the magnetic device, please carefully consider all risk assessments of any lift taking place. Take care to read the operating instructions in full, in order to prevent and avoid any accident.

Care to be taken to avoid any impact or bump of the magnetic lifter when out of service. Internal damage could occur which will probably affect its lifespan but could also cause potential for lifting in an unsafe manner.

Never bump the magnetic lifter handle or damage the workpiece holding contact surface. When not in use it is good and safe practice to protect the magnetic lifter holding surface area by applying anti-rust oil.

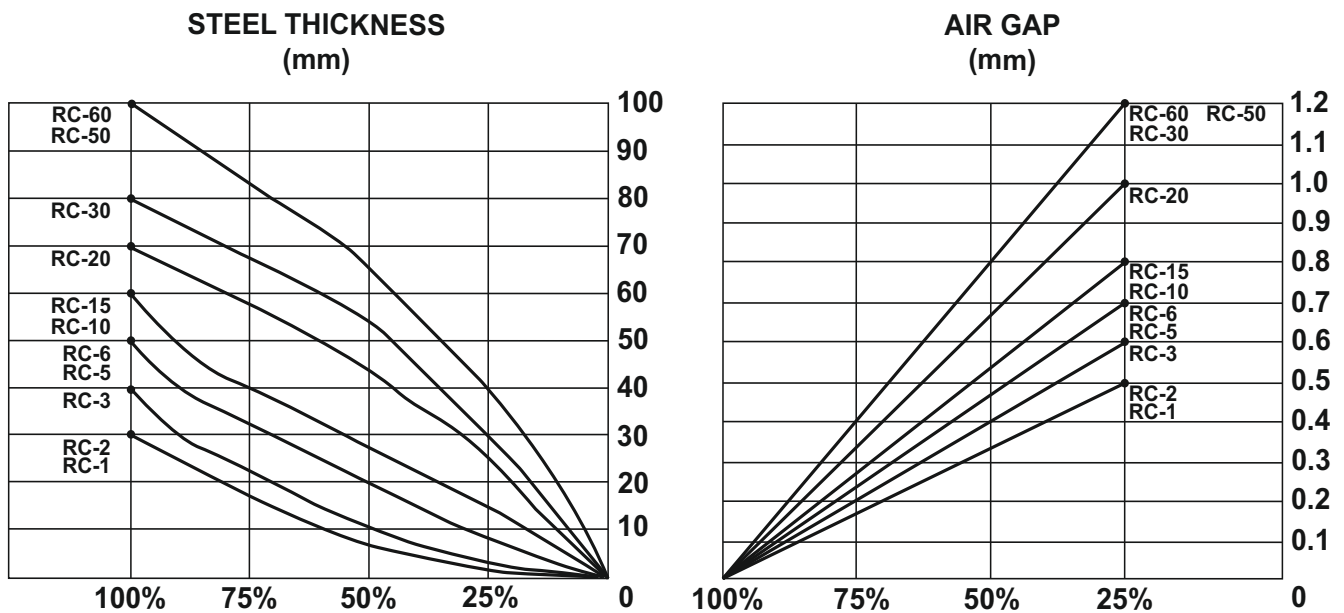

SAFETY CAPACITY CURVE

Thickness (mm)	Effective percentage of rated capacity						
	RC-60 RC-50	RC-30	RC-20	RC-15 RC-10	RC-6 RC-5	RC-3	RC-2 RC-1
100	100%	100%	100%	100%	100%	100%	100%
90	85%	100%	100%	100%	100%	100%	100%
80	70%						
70	55%	80%	80%	90%	90%	90%	80%
60	45%	60%					
50	35%	45%	60%	90%	90%	90%	80%
40	25%	35%	45%	75%			
30	-	25%	30%	55%	70%	90%	80%
20	-	-	20%	35%	50%	70%	80%

Safety Capacity Data for Thickness (Reference)



Permanent Magnet Lifter Manual

Maintenance & Specifications

Inspect the handle frequently and before each lift, to make sure its slide key can move easily and is flexible. The top pin should always be able to lock firmly. This should be checked prior to each lift.

It is strictly forbidden to turn the magnetic lifter's handle without the iron/steel workpiece being in contact with its intended holding surface.

Users should be trained and competent people, who must have read and understood these safe use instructions. Maintenance must be executed by authorised or professional technicians, who must strictly follow the instructions and guidelines.

It is forbidden to modify the magnetic lifter in any way.

The magnetic lifter should be inspected and tested with data recorded at least once every year and/or to suit the legal requirements of the working country of use.

If its main body shows any visible signs of damage or any of the moving parts are damaged in any way, then the unit should be removed from service and destroyed to avoid any possibility of future use.

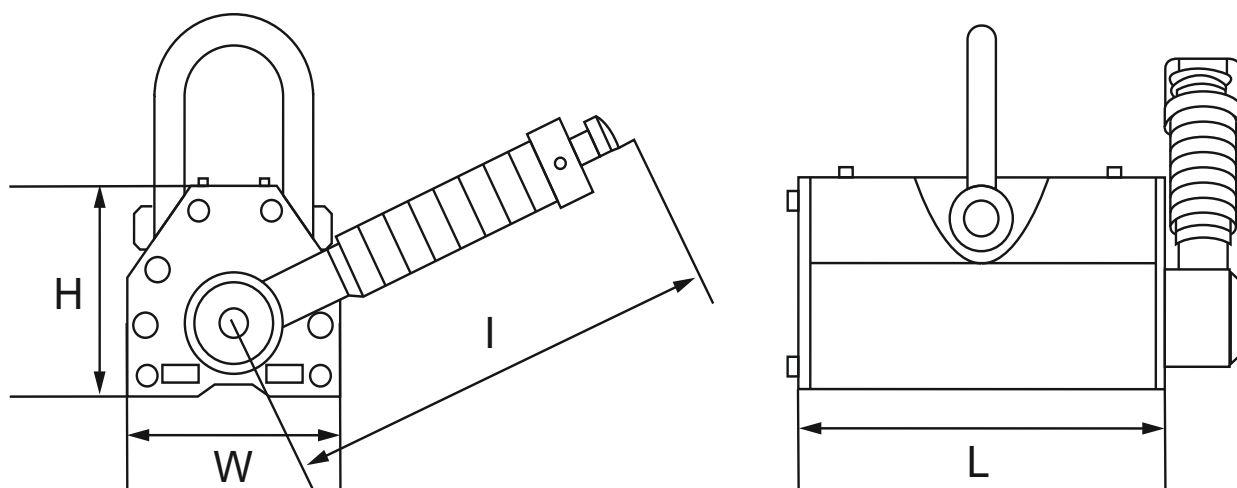

Part No.	Plate Capacity kgs	Cylindrical Capacity kgs	Tear-off Force kgs	H mm	I mm	L mm	W mm	Weight kgs
RC-1	100	30	350	70	142	92	64	3
RC-3	300	100	1,050	96	176	165	88	10
RC-6	600	200	2,100	120	219	236	118	24
RC-10	1,000	300	3,500	168	266	264	168	50
RC-20	2,000	600	7,000	217	462	378	230	125
RC-30	3,000	1,000	10,500	265	567	453	290	220
RC-50	5,000	1,500	17,500	265	707	647	290	355
RC-60	6,000	2,000	19,200	265	707	713	290	398